



2009 AUSTRALIAN OFF ROAD CHAMPIONSHIP



SPORTING REGULATIONS

Version 1

Bulletin B09/002

2009 Australian Off Road Championship Sporting Regulations

See also General Conditions for Australian Titles (Section 2)

1. GENERAL

All events in the Australian Off Road Championship will be held under the provisions of the International Sporting Code of the FIA, the National Competition Rules of CAMS, General Conditions for all Titles, Off Road Standing Regulations, these Sporting and Technical Regulations and the Supplementary Regulations published by the organisers of each event, as well as any further regulations or instructions which may be issued.

2. ADVERTISING

- 2.1 By entering any event in the Championship, persons and corporations agree to refer to it only by its full title, "The 2009 Australian Off Road Championship".
- 2.2 Any promotional material must include the full title.
- 2.3 Each vehicle is required to display the CAMS logo on each side of the car, in the vicinity of the competition number, together with any series sponsorship signage which may be required.
- 2.4 An event organiser may also require each competitor to display signage promoting the event sponsor: in such cases this requirement is to be included in event supplementary regulations, and the organisers shall provide this signage to competitors.

3. CHAMPIONSHIP SCHEDULE

- 3.1 The 2009 Australian Off Road Championship will consist of the following events:

Rd 1: Hyden 400, WA	April 11-12
Rd 2: Finke Desert Race, NT	June 6-8
Rd 3: Sunraysia 500, Vic	July 25-26
Rd 4: Pines Off Road Enduro, SA	September 12-13
Rd 5: Goondiwindi 400, Qld	October 17-18

Note: Each of the five rounds counts toward the outright Championship.

4. EVENTS

4.1 Starting order

- (i) The starting order for the first section is to be determined by a prologue.
- (ii) The starting order for the second and any subsequent sections is to be based on the outright finishing order of the preceding section, as varied by the inclusion of any crews/drivers restarting the event as provided for in Article 4.12 of these regulations.
- (iii) After consultation with AORCom, organisers shall advise each crew/driver of the prologue start order upon seeding of each class in the prologue field. This advice is to be made available not later than 24 hours before the first briefing to allow crews/drivers to identify potential problems. The latest acceptable time for bringing such problems to the attention of the organisers is the scheduled start time for the first crew briefing.
- (iv) Other than as provided for in the preceding paragraph, all crews/drivers are to start the prologue at the times allocated to them by the organisers, without exception.
- (v) For the prologue, each vehicle will be grouped by class.
- (vi) The crew and vehicle combination completing the prologue course in the least time will start first, followed by the remainder of the field in increasing order of time taken over the prologue course.

(vii) The prologue shall be conducted in daylight.

4.2 Seeding

- (i) A crew/driver not finishing the prologue may, on application, be seeded.
- (ii) Seeding will be on the basis of the average of a driver's three previous prologue results, relative to the rest of the field, and where a driver is seeded the data base will record the starting position allocated plus 10 positions.
- (iii) No driver who has applied to be seeded may be seeded within the top 10% of cars starting the event, if fewer than 100; and not within the top 10 cars if more than 100.
- (iv) There is no right of appeal against any decision with regard to seeding.
- (iv) Except as otherwise provided for in Article 7 of these regulations, the driver/co-driver combination which attempts the prologue (or applies for seeding) must start the event in the same respective roles.

4.3 Competition numbers

- (i) Each driver shall use their current annual national competition numbers allocated by CAMS. If a permanent number has not been allocated, the organiser will allocate a competition number to be used for the event.
- (ii) Competition numbers must comply with General Requirement 30 for Off Road Vehicles.

(iii) The numbers 1, 2 & 3 are reserved for the exclusive use of the first three drivers in the preceding year's AORC.

The first three competition numbers in each class (e.g.; 101, 102, 103, 201, 202) are reserved for the exclusive use of the first three drivers in each class in the preceding year's AORC.

A driver who is eligible to use one of these numbers due to achieved results shall utilise the reserved number at each AORC event of the following year.

A driver required to utilise 1,2 or 3 or one of the first three competition numbers in each class may apply to CAMS for their existing competition number to reserve it.

4.4 Timing

- (i) Timing shall be to the hundredth of a second using the 24 hour system.
- (ii) Vehicles shall be timed as their front wheels pass the timing marker of the control, or if an electronic beam is utilised, when the beam is broken.
- (iii) The results of each event will be determined by the total elapsed time taken by vehicles for all sections of the event, to which have been added any penalties.

4.5 Finishers

- (i) To qualify for outright points and awards in the outright Australian Off Road Championship, drivers and co-drivers must complete all sections of the event.
- (ii) To qualify for class points or awards, drivers and co-drivers must complete at least one section.
- (iii) To be credited with having completed a lap, the vehicle must pass through all passage controls in the correct direction, and reach the finish line at the end of each section under its own power, with the crew correctly seated in the vehicle.
- (iv) To be credited with completing a section, a car must complete the prescribed number of laps and reach the finish line within the time limit specified by the organisers.

4.6 Judges of Fact

Each control official will be a judge of fact with regard to time and direction of entry into controls.

4.7 Protests

A protest must be lodged in accordance with the provisions of Part XII of the NCR.

4.8 Postponement, abandonment and cancellation

The organising committee may postpone, abandon or cancel the event at any point in accordance with the NCR; or cancel the event should the number of entries received be less than the minimum as specified in the event supplementary regulations.

4.9 Outside servicing

- (i) Servicing of a competing vehicle during an Australian Off Road Championship event other than in the designated pits is prohibited. This prohibition shall not apply where such servicing;
 - (a) is carried out only by a crew member of a vehicle which started in the competition (that section), whether it be the vehicle in question or another competing vehicle,
 - (b) uses no parts or equipment other than those which have been carried from the pits, after the start of the event, in a vehicle which started the event (in either the vehicle in question or another competing vehicle), or which have been carried from the pits by a crew member of the vehicle in question, on foot, without any assistance outside the pit/paddock area,
 - (c) uses articles/material which might normally be found in the region, eg water, fencing wire, string and the like, (other than as provided for above this does not apply to automotive components or tools) and/or
 - (d) is rendered by an official recovery crew, with that crew's agreement, and which takes the form of:
 - towing to the next accessible passage control, or the next recovery point,
 - provision of tools, but NOT parts, and/or
 - provision of water.
- (ii) Notwithstanding the provisions of Art 4.10 (i), the Clerk of the Course or his nominated deputy may provide written permission for pit crews to provide assistance at a passage control or recovery point, or for crews to be carried from the course to the pits and back again; this permission being valid for one instance only.

4.10 Refuelling

The organiser is to establish a designated "refuelling area", specifically set aside for the purpose of refuelling. Except as specifically otherwise provided for in the regulations applicable to the event, refuelling outside these areas is prohibited. If a vehicle runs out of fuel on the course, the Clerk of the Course or his nominated deputy may give written permission for that vehicle to be refuelled on the course, provided always that safety is not compromised in any way.

4.11 Reconnaissance

- (i) The Organiser is to provide each crew/driver with the opportunity to undertake reconnaissance of the entire course, and the prologue course, in daylight within 48 hours of the start of the event.
- (ii) It is recommended that drivers be allowed to use either their competition vehicles or suitable road car, with those using non-competition vehicles not being allowed to start until those in competition vehicles have had reasonable opportunity to do so. Where competitors are unable to use

their competition vehicle due to registration requirements or where they do not have access to a suitable road vehicle, competitors may make application to the organisers no later than 7 days prior to the event to be transported over the competition course during reconnaissance as arranged by the organiser.

- (iii) Each occupant in a vehicle being utilised on the reconnaissance must wear a seat belt at all times.
- (iv) Each competition vehicle utilised in reconnaissance shall be checked by the event scrutineers beforehand. Where this vehicle is not fitted with a windscreen, a helmet and visor complying with Schedule D shall be worn by each occupant.

4.12 Starting position after failing to finish a section

- (i) A crew/driver who fails to finish a section may start a subsequent section provided they are able to satisfy the Chief Scrutineer that the vehicle is in a safe and competition ready condition; and will, should he make application within the prescribed timeframe, be seeded.
- (ii) Such a seeding is to be effected using the same criteria as for a driver who is seeded after failing to finish a prologue. No driver who has applied to be seeded may be seeded within the top 10% of cars starting the event, if fewer than 100; and not within the top 10 cars if more than 100.
- (iii) Such seedings are to be referred to the stewards of the meeting for approval.
- (iv) There is no right of protest or appeal against any decision with regard to seedings.

5. REGISTRATION

- (i) National competition number application *and* Registration for the 2009 Australian Off Road Championship is required in order to be eligible to score championship points.
- (ii) A crew/driver will be eligible to score points in events conducted after the application is received, and this must be received by CAMS prior to the completion of documentation. At an AORC event, registration applications shall be lodged with the CAMS Stewards.
- (iii) A non-registered crew/driver may enter an AORC event, but will only be eligible for event results and awards (not points) and will be disregarded for the compilation of the AORC point score.

6. COMPETITOR/CREW/DRIVER ELIGIBILITY

- (i) For competition licence requirements refer to Section 2 – General Regulations of CAMS.
- (ii) At least one member of each crew must hold a valid civil driver's licence, or be at least 18 years of age.
- (iii) The entry list of each event shall reflect which competition/s each entered crew is eligible for and the co-driver/navigator nominated for AORC points. The entry list shall be submitted to CAMS for approval prior to publication.

7. CREWS

- (i) Except for Pro Buggy, Prolite Buggy and Extreme 2WD vehicles fitted with only one seat, where crews consist of only the driver, two persons shall comprise the crew of any competing car at any time, and shall be nominated as “driver”, “co-driver” or “navigator” as appropriate. The participation of more than one navigator appropriately nominated on the entry form is permitted.
- (ii) Crew changes are permitted, subject to the following conditions.

(a) A driver who starts the event may be replaced only by the co-driver. The original driver may resume driving the same vehicle later in the event.

(b) A co-driver may be replaced by either the driver who started the event in that vehicle, or by a navigator: the latter who may navigate only.

(c) To be classified as a finisher, a vehicle must be driven by the driver who starts the event in that vehicle for at least 75% of the distance specified by event organisers. Where this is not possible due to the event format, 50% of the distance specified will be the minimum portion of the event required to be driven by the driver who starts the event, who shall score AORC points.

(d) No driver may be nominated as a number one driver in more than one vehicle in an event.

(iii) Where a co-driver or navigator, becomes incapacitated through either sickness, injury or other extenuating circumstances prior to or during an event, that person may, subject to the permission of the Clerk of the Course, be replaced by a co-driver or navigator who has already been entered as such on an entry form as a crew member for another entry in that event.

(iv) Where the requirements for drivers and navigators vary between state championship and national championship, in dual status events these variances must also appear in event supplementary regulations. Where a conflict exists, the AORC requirements shall take precedence.

8. CREW ATTIRE

During competition, each crew member is required to wear apparel which complies with the provisions of Schedule D – Apparel, Article 1 & 3(d). The wearing of a head restraint in accordance with Schedule D, Article 4 is highly recommended.

9. CREW BRIEFING

9.1 There are to be two briefings for crews/drivers; at least one on the day of, and before, the prologue and one before competition on subsequent days of the event.

9.2 Attendance at each crew briefing is compulsory for each crew member. The organiser shall provide a list showing car number, and the names of drivers, co-drivers and navigators. Each competing crew member shall sign on. The sign-on sheets are to be made available to crews/drivers for a period commencing 20 minutes prior to the scheduled start time for each crew briefing, and shall be removed at the scheduled start time.

9.3. The time and place of crew briefings is to be specified in event supplementary regulations. Cases of non-attendance are to be referred to the Stewards by way of a formal charge, which may result in a penalty.

10. VEHICLE ELIGIBILITY

10.1 Each vehicle shall comply with the requirements of Section 12 and be eligible for one of the listed Classes at Article 4.2 of the Off Road Standing Regulations, except Clubman Buggy which are ineligible for the Championship.

10.2 A space 140mm high x 500mm wide immediately under the crew's side 'window' opening is reserved for AORC sponsorship signage on each side of the car. If this signage is not outlined in the supplementary regulations, competitors may utilise this space for their own purposes.

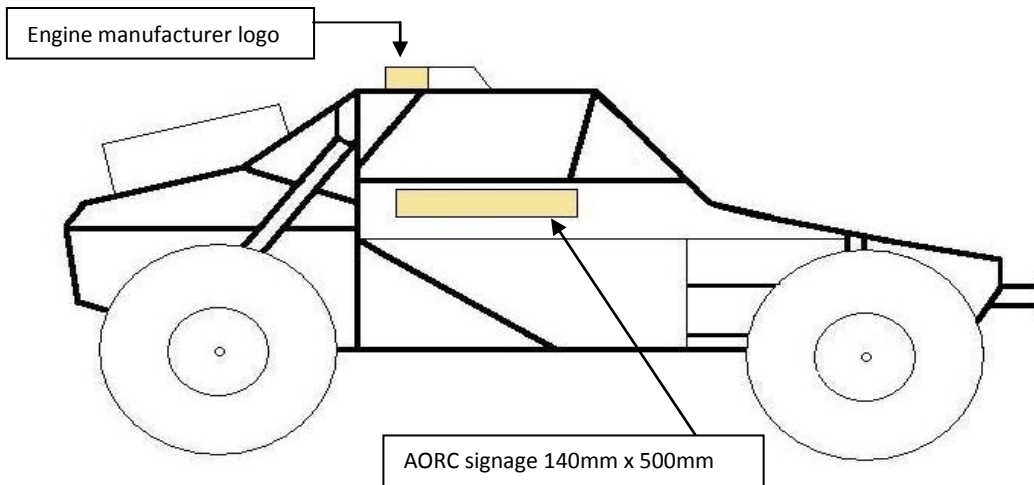

10.3 Each buggy driven by a driver registered for the AORC shall carry the logo of the manufacturer of the engine fitted to the car next to the roof number. The minimum size of this logo is 100mm x 100mm.

11. SCRUTINY

- 11.1 Each competition vehicle shall be examined by the event scrutineers prior to starting the event. The time and place for such examination will be advised in supplementary regulations. Further vehicle checks may be conducted throughout the event.
- 11.2 "Regional" pre-event scrutiny may be provided, subject to the regional scrutineer being approved by the AORC Technical Commissioner prior to such scrutiny being conducted. Random checks of vehicles approved at regional scrutiny are to be conducted at events.
- 11.3 A competition vehicle may be examined for eligibility at any time before or after finishing, up to 30 minutes after the conclusion of the event.
- 11.4 Immediately upon the completion of the event, the cars which fill first, second and third places outright, and first place in each class, shall be impounded by the organisers for possible post-event eligibility scrutiny. Other cars may also be impounded at the organisers' or Technical Commissioner's discretion.
- 11.5 Vehicles impounded by virtue of either their outright or class finishing positions shall be held in impound for at least 20 minutes. Examination for compliance may be undertaken whilst the vehicle is impounded and competitors may be required to provide mechanical assistance to the scrutineers undertaking such examinations.

12. PARC FERMÉ

- 12.1 For regrouping or other reasons, vehicles may be required to be held in a *parc fermé*. Any vehicle which enters a *parc fermé* with its engine running may be restarted with assistance from officials before its release time.
- 12.2 When *parc fermé* conditions are imposed prior to the conclusion of an event, eg for regrouping, the *parc fermé* is to be located so that it is possible for crews/drivers to go directly to the pits on release from *parc fermé* should they wish.

13. CHAMPIONSHIP & SERIES POINTS

- 13.1 **Outright Championship:** An outright Champion Driver and Co-driver, to be known as the Australian Off Road Champion Driver and Australian Off Road Champion Co-driver respectively, will be recognised. Points will be allocated to the drivers/ co-drivers who fill the first 10 places outright for the event, on the following scale:

1 st	2 nd	3 rd	4 th	5 th	6 th	7 th	8 th	9 th	10 th
20	15	12	10	8	6	4	3	2	1

13.2 Class Championships

- (i) The winner of each eligible class shall be known as the Australian Off Road (*insert relevant class name*) Class Champion Driver and Co-driver respectively, will be recognised. The winner will be the driver and co-driver to earn the most “class points” in their respective class throughout the Championship.

13.3 Class Championships - Points Allocation

Class points will be allocated to the drivers/co-drivers who fill the first 20 places in their class, as follows:

- (i) **Event is run as one section**

The allocation of class points will be as follows:

Section 1

1 st	2 nd	3 rd	4 th	5 th	6 th	7 th	8 th	9 th	10 th	11 th	12 th	13 th	14 th	15 th	16 th	17 th	18 th	19 th	20 th
160	140	120	112	96	88	80	72	64	56	48	40	32	28	24	16	8	6	4	2

- (ii) **Event is run in two sections**

The allocation of class points will be as follows:

Section 1

1 st	2 nd	3 rd	4 th	5 th	6 th	7 th	8 th	9 th	10 th	11 th	12 th	13 th	14 th	15 th	16 th	17 th	18 th	19 th	20 th
80	70	60	56	48	44	40	36	32	28	24	20	16	14	12	8	4	3	2	1

Section 2

1 st	2 nd	3 rd	4 th	5 th	6 th	7 th	8 th	9 th	10 th	11 th	12 th	13 th	14 th	15 th	16 th	17 th	18 th	19 th	20 th
80	70	60	56	48	44	40	36	32	28	24	20	16	14	12	8	4	3	2	1

- (iii) **Event is run in three sections**

The allocation of class points will be as follows:

Section 1

1 st	2 nd	3 rd	4 th	5 th	6 th	7 th	8 th	9 th	10 th	11 th	12 th	13 th	14 th	15 th	16 th	17 th	18 th	19 th	20 th
52	46	40	36	32	29	26	23	20	18	16	14	12	10	8	6	4	3	2	1

Section 2

1 st	2 nd	3 rd	4 th	5 th	6 th	7 th	8 th	9 th	10 th	11 th	12 th	13 th	14 th	15 th	16 th	17 th	18 th	19 th	20 th
52	46	40	36	32	29	26	23	20	18	16	14	12	10	8	6	4	3	2	1

Section 3

1 st	2 nd	3 rd	4 th	5 th	6 th	7 th	8 th	9 th	10 th	11 th	12 th	13 th	14 th	15 th	16 th	17 th	18 th	19 th	20 th
56	48	40	36	32	30	28	26	24	20	16	14	12	10	8	6	4	3	2	1

- (iv) **Event is run in four sections**

The allocation of class points will be as follows:

Section 1

1 st	2 nd	3 rd	4 th	5 th	6 th	7 th	8 th	9 th	10 th	11 th	12 th	13 th	14 th	15 th	16 th	17 th	18 th	19 th	20 th
40	35	30	28	24	22	20	18	16	14	12	10	8	7	6	5	4	3	2	1

Section 2

1 st	2 nd	3 rd	4 th	5 th	6 th	7 th	8 th	9 th	10 th	11 th	12 th	13 th	14 th	15 th	16 th	17 th	18 th	19 th	20 th
40	35	30	28	24	22	20	18	16	14	12	10	8	7	6	5	4	3	2	1

Section 3

1 st	2 nd	3 rd	4 th	5 th	6 th	7 th	8 th	9 th	10 th	11 th	12 th	13 th	14 th	15 th	16 th	17 th	18 th	19 th	20 th
40	35	30	28	24	22	20	18	16	14	12	10	8	7	6	5	4	3	2	1

Section 4

1 st	2 nd	3 rd	4 th	5 th	6 th	7 th	8 th	9 th	10 th	11 th	12 th	13 th	14 th	15 th	16 th	17 th	18 th	19 th	20 th
40	35	30	28	24	22	20	18	16	14	12	10	8	7	6	5	4	3	2	1

- (v) Crews/drivers completing the whole course, (i.e. each section comprising an event) within the allotted time, will be allocated five additional points per round.
- (vi) Following the conclusion of the AORC series, a trophy will be presented to the **Champion/s** of each class.

13.4 Tri-Series

The Tri-Series is a series run as part of the AORC and shall consist of the following:

- (i) For a crew to be eligible, the driver must not have finished in the top 15 outright and must not have won a class in the previous year's AORC. The following drivers are **not** eligible for the 2009 Tri-Series:
Shannon Rentsch David Fellows Brad Prout
Hayden Bentley Brad Gallard Terry Rose
Danny Brown Eric Phillips Brett Taylor
Travis Milburn James Madden Chris Coulthard
Buddy Crowe Glen Owen Wayne Bannan
Justin Watt Cameron McClelland Damien Penfold
Grant Bowden Geoff Pickering Colin Hunter
- (ii) A maximum of three (3) rounds will count towards the point score for each eligible crew member.
- (iii) The driver may nominate to compete in any three rounds of the Championship.
- (iv) The rounds in which crews will score points must be nominated prior to the close of documentation of the first event in which the crew wishes to compete. A list of nominated rounds for each Tri-Series registered crew shall be published.
- (v) The crew may compete in more than three rounds of the AORC, but points towards the Tri-Series will only be scored in these three nominated events.
- (vi) The nominated rounds of the Tri-Series may be changed. The latest time to do so is prior to the completion of documentation of a nominated event. If a change is to occur at an event the Stewards must be advised, or if remote from an event, the competitor must advise the CAMS Off Road Department, in writing or via email, preferably by re-submission of the Tri-Series round nomination form.
- (vii) The Tri-Series shall have an 'Outright' and overall 'Class' winner, with points scored in the same manner outlined in Article 13.3.
- (viii) A trophy will be awarded to each member of the winning crew.

13.5 Co-drivers/Navigators: The co-driver or navigator nominating for points shall have a "*P*" in italics after his name on all documents. The point scoring co-driver/navigator will only be eligible if he completes at least one section, or the total distance covered by the car, whichever is the lesser, and provided that the car is classified as a finisher.

13.6 Bonus Points: The final round of the AORC each year will be a bonus round. Outright and Class points outlined in 13.1 and 13.3 shall be multiplied by a factor of 1.5 in the final round. *This provision shall not apply to the Tri-Series.*

13.7 Shortened Events

- (i) Outright Points

Where an event is stopped or otherwise shortened for any reason, Outright championship points will be awarded as follows.

(a) If the leading vehicle at the time has completed less than 25% of the scheduled distance, no points will be awarded.

(b) If the leading vehicle has completed 25%, but less than 75%, of the scheduled distance, points will be awarded at 50% of the normal scale applicable.

(c) If the leading vehicle has completed 75% or more of the scheduled distance, points will be awarded as though the scheduled distance had been covered.

(ii) **Class Points**

Where an event is stopped or otherwise shortened for any reason, Class Championship points will be awarded as follows.

(a) Where the event is run as one section, points will be awarded on the same basis as Outright championship points.

(b) Where the event is run as two or more sections, points will be allocated for those sections completed, in accordance with the appropriate scale (for the number of sections scheduled) in Art 13.3 (ii), (iii), or (iv) above. No points will be awarded for any section not completed or which is stopped before the scheduled time for completion.

13.8 Non-Registered Crews/Drivers

The results of crews/drivers who have not registered for the AORC are to be disregarded when computing the point score.

14. PRESENTATION OF AWARDS

Following each event, organisers are to conduct a presentation ceremony, usually in the vicinity of the finish. In order to ensure that the public and others are able to properly identify and honour the winners, a podium should be prepared.

15. MEDIA CONFERENCE

Award winning crews may be required to attend a media conference, which will take place as close as practicable to the presentation area. Crews are reminded of their obligations to event sponsors, and should present themselves accordingly.

16. PRIZE MONIES

(i) Outright prize money is to be paid on the following basis:

(a) first place - a minimum of an amount equal to one entry fee for the event, inclusive of sundry levies and add-ons.

(b) second - a minimum of an amount equal to two thirds of the entry fee for the event, inclusive of sundry levies and add-ons.

(c) third - a minimum of an amount equal to one third of the entry fee for the event, inclusive of sundry levies and add-ons.

(ii) The provision of prize money based on class placings is optional.

17. JUDICIAL PROCEDURES

(i) The object of these rules is to provide for the expeditious inquiry by the stewards into, and determination of, any matter referred to them and of any alleged dispute, protest or offence.

(ii) Inquiries pursuant to these rules will be undertaken jointly by the Stewards of the Meeting.

(iii) Inquiries will be inquisitorial in nature, and the stewards may regulate any inquiry in such manner as they see fit in all the circumstances of the case, subject only to the rules of natural justice.

(iv) To facilitate the conduct of an inquiry a person, if requested by the stewards, must;

- (a) upon receiving a request to do so, appear before the stewards,
- (b) fully cooperate in good faith with the stewards,
- (c) provide a full and truthful account to the best of their knowledge to the stewards,
- (d) fully and truthfully answer any questions asked by the stewards, and
- (e) not make any false or misleading statement to, or make a statement either calculated or likely to mislead the Stewards.
- (v) All persons thought by the stewards to be able to assist them may be required to attend the inquiry. Notice to attend will normally, but not necessarily, be in writing and will include brief details of the matter under investigation.
- (vi) If in the opinion of the Stewards a person:
 - (a) fails to comply with the provisions of 17(v) or
 - (b) in any way obstructs an inquiry being undertaken by the Stewards, that person will be deemed to have committed an offence against these rules and may be dealt with by the Stewards.
- (vii) Before commencing any inquiry the stewards must inform all relevant persons the subject of the inquiry, of the nature of the matter referred to them, or of the alleged dispute or offence; and that as a result of the inquiry penalties may be imposed.
- (viii) Normally the calling of witnesses and the majority of questioning will be conducted by the stewards.
- (ix) Any person or persons who have been advised that as a result of the inquiry action might be taken against them must be made aware of all evidence against them and be given the opportunity to call evidence on their own behalf, ask questions and make submissions in relation to the matter.
- (x) Should guilt be established, any submission to be put to the stewards with regard to penalty will be made, to avoid the necessity for a separate re-convening of the hearing to consider an appropriate penalty.
- (xi) Decisions will normally take effect immediately they are made.
- (xii) Affected persons will be advised of any decision as soon as is practicable after it has been made.
- (xiii) Where possible, written decisions will be provided as soon as practicable after the completion of the inquiry.
- (xiv) In addition to penalties provided in the National Competition Rules the Stewards may also apply;
 - (a) a penalty by way of the deduction of championship points, up to a maximum of 20 points, on a crew member in any section of an event for a breach of the NCRs, the Supplementary Regulations or Sporting Regulations, or
 - (b) a penalty by way of the addition of time, up to a maximum of 60 minutes per breach, to the total elapsed time in any section of the event for a breach of the NCRs, the Supplementary Regulations or Sporting Regulations.
- (xv) All persons affected by or concerned in an inquiry will be bound by the decisions or determinations of the Stewards of the Meeting, subject only to the rights of appeal pursuant to Part XIII of the NCRs.

18. PENALTIES

- (i) The following are offences against these regulations, and are to result in the imposition of the specified penalties:

- (a) Failure to comply with specified control procedure: – *time penalty of 30 minutes*
- (b) Shortcutting or other deviation from the course:
 - first breach during the event: – *30 minutes*
 - second breach during the event: – *exclusion**
 - any breach during the prologue – *3 minute per instance*
- (c) Causing damage to property, deemed by the Clerk of the Course to have been deliberate: – *exclusion**,
plus any additional penalty which may be imposed by the Stewards of the event
- (d) Refuelling whilst the vehicle engine is not switched off – *exclusion**
OR
whilst any person is inside the vehicle – *exclusion**
OR
whilst the vehicle is not totally inside any designated refuelling area – *exclusion**
- (e) Breach of *parc fermé* regulations – *100 minutes*
- (f) **False Start / Jumping the Start**
 - Prologue – *1 minute*
 - Event proper – *5 minutes*
- (g) Receiving outside servicing, other than as provided for in Article 4.9 – *exclusion**
- (ii) Any time penalties awarded are to be imposed at the conclusion of the prologue/event (rather than the section in which the infringement was committed) as applicable. Any time penalty awarded for an infringement during the event proper will not affect the running order on the track.
- (iii) Penalties may only be imposed by the Stewards of the Meeting.

** Under the provisions of NCR 192 a penalty of exclusion may only be imposed by the Stewards of the Meeting.*

ENDS